

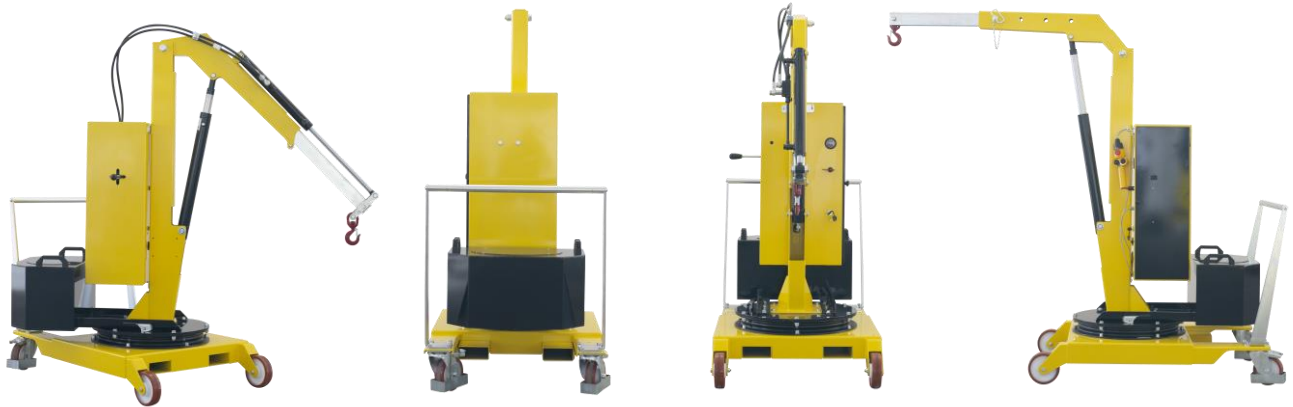

Flexibility, innovation and safety for your work

## COUNTERBALANCED 360° SWIVEL CRANES



A complete range of counterbalanced 360° swivel cranes with manual traction, , **with a maximum capacity up to 500 kg and outreach up to 1300 mm**. Hydraulic lever controlled or electric controlled. They represent the most cost-effective and flexible solution for lifting and transporting loads in several applications such as machining centers and machine tools, delivery to assembly lines, assembly operations, goods handling. Thanks to their compact dimensions they are easily maneuverable even at full load and can be moved effortlessly in confined spaces. All components are made in Italy to ensure the highest construction quality and the absence of defects.

The hydraulic system is equipped with a lock valve that prevents the load from falling in case of accidental breakage of the pipes and a rough valve that prevents overloading of the crane.

They are equipped with 2 high-capacity pivoting wheels with bumper mounts and parking brakes and with 2 fixed front wheels with bearings. The frame is made of painted steel and is equipped at the base with 2 useful forklift supports (to lift and transport the crane in complete safety on long distances). The sturdy push handle can be disassembled. There are also 2 handles to easily rotate the ballast. Swivel hook type. Rotating Jib arm with 8 locking positions.

### CERTIFICATION AND COMPLIANCE WITH REGULATIONS FOR THE PROTECTION AND SAFETY IN THE WORKPLACE

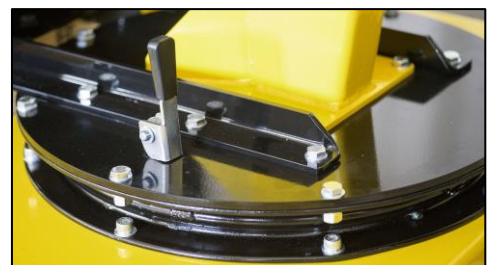
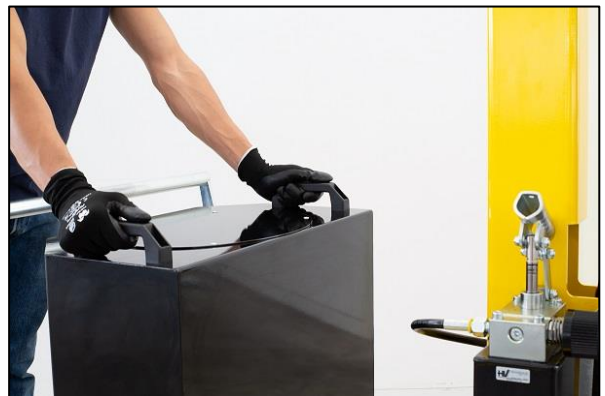

# 01B5

**CAPACITY 500 KG**

**COUNTEDBALANCED SWIVEL CRANE LIFT/LOWER POWERED CONTROLLED**

**SINGLE SPEED NOT ADJUSTABLE**

Technical data	UM	01B5
Weight	[kg]	640
Max capacity	[kg]	500
Max pressure	[bar]	140
Tank capacity	[Liters]	2,5
Cylinder stroke	[mm]	470

CAPACITY AND DIMENSIONS WITH STANDARD JIB ARM		
POS.	Length [mm]	Capacity
		01B5 [kg]
1	365	500
2	500	420
3	635	370
4	770	320

CAPACITY WITH OPTIONAL EXTENDED JIB ARM		
POS.	Length [mm]	Capacity
		01B5 [kg]
1	865	220
2	1000	200
3	1135	180
4	1270	160

The arm is extendable in 4 positions and an optional arm extension is available to get a maximum outreach of 1270 mm.



Model 01B5 is equipped with a lift/lower system controlled by pendant push button with emergency stop.



Built-in high-frequency charger.  
Charge level indicator. Battery 12V 80A.

1 battery	[V]	12
	[A]	80
Battery charger	[V]	220
	[A]	12

# 01B5

## TECHNICAL DRAWINGS, DIMENSIONS AND CAPACITIES

Recommended for lifting operations that do not require an accurate load positioning in the descent phase

### STANDARD EXTENSION

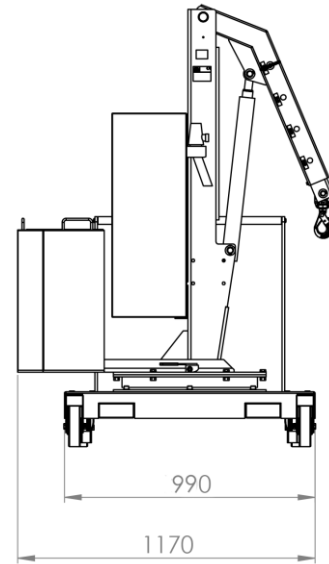
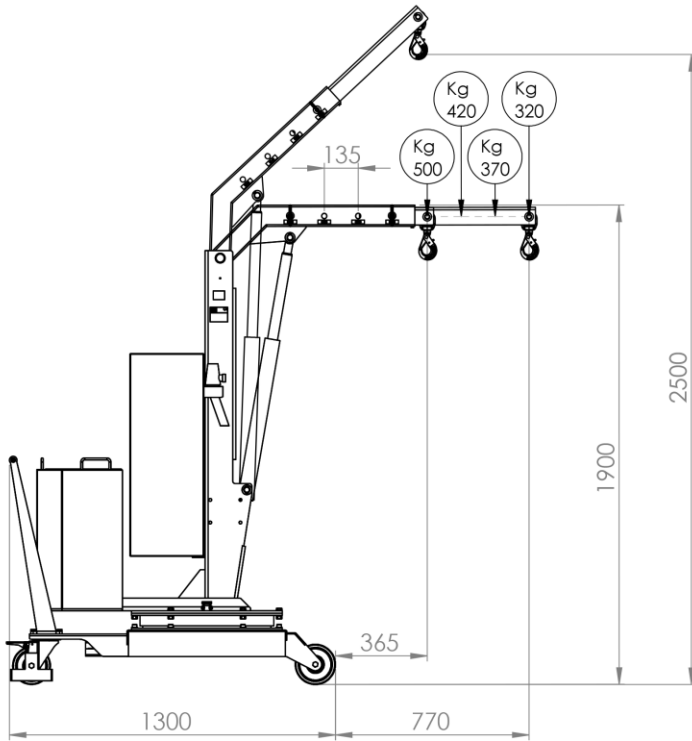

### OPTIONAL EXTENSION

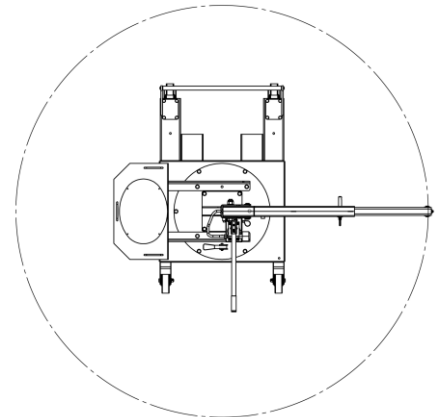
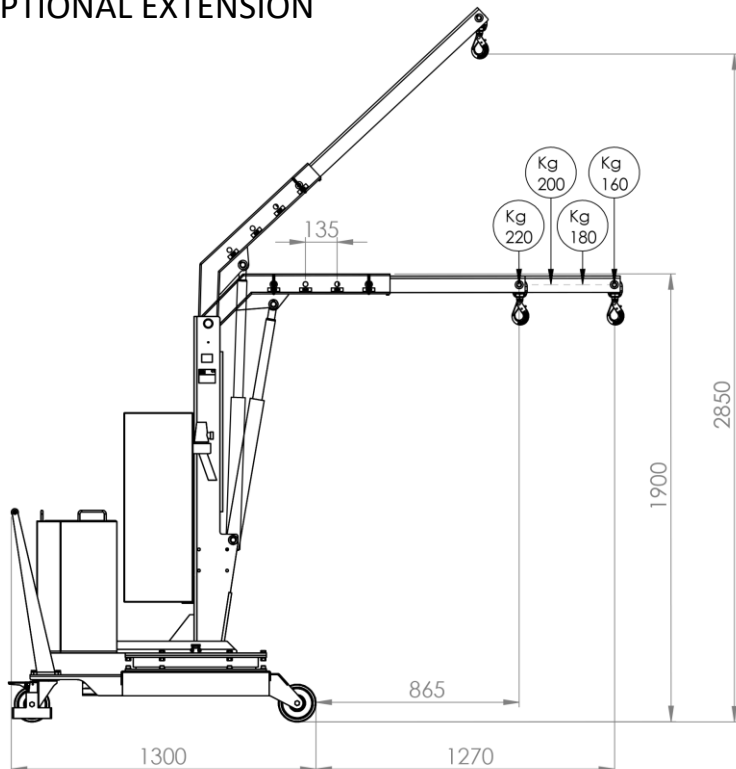

# 01B5

## TECHNICAL DRAWINGS, DIMENSIONS AND CAPACITIES

Recommended for lifting operations that do not require an accurate load positioning in the descent phase

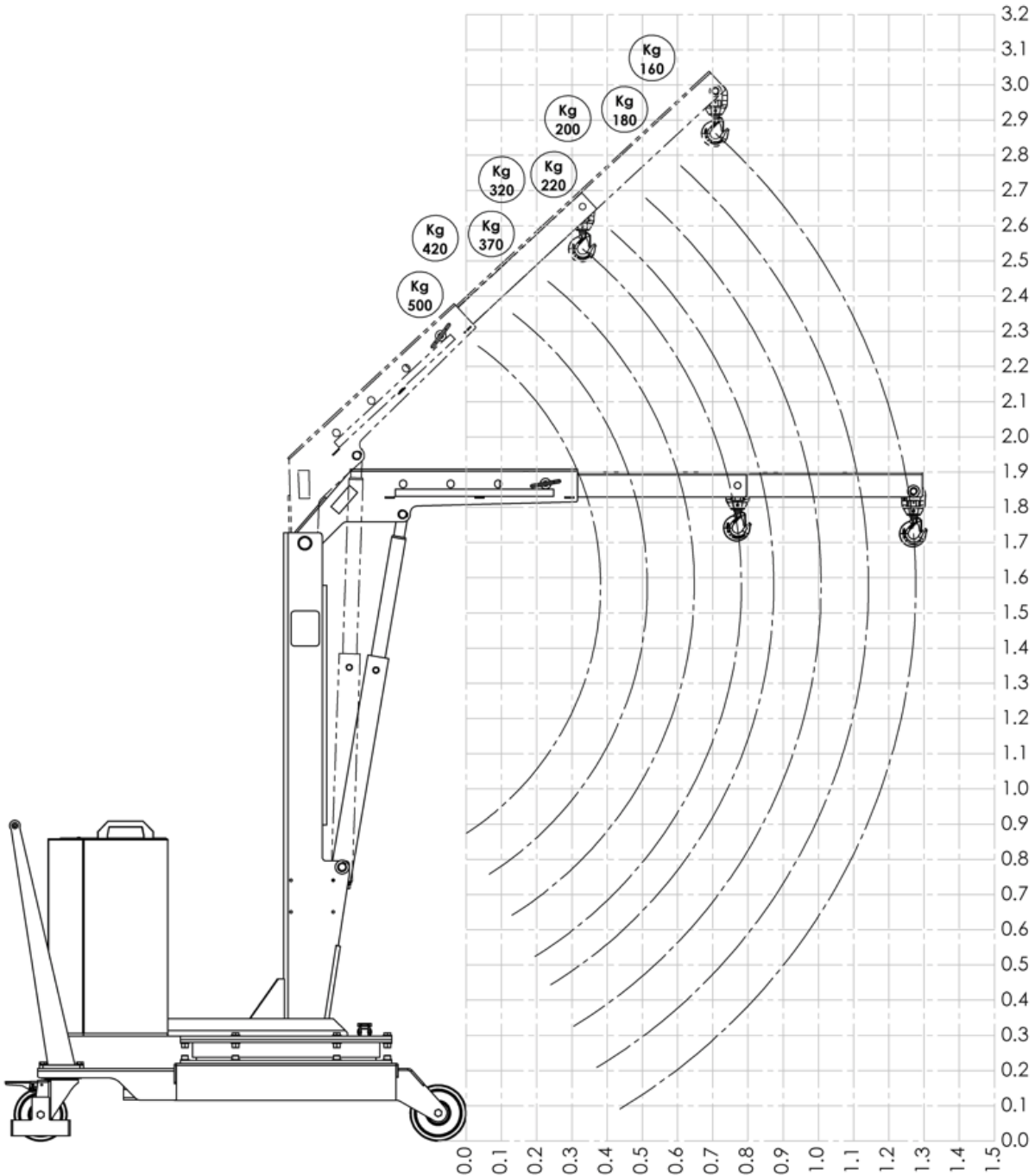





Flexibility, innovation and safety for your work

**A COMPLETE RANGE  
OF COUNTERBALANCED 360° SWIVEL CRANES FOR ANY APPLICATION  
SPECIAL CRANES AND CUSTOM PROJECTS ON DEMAND**

**IN COMPLIANCE WITH SAFETY REGULATIONS  
TO ENSURE YOUR PRODUCTIVITY**



*We make value and safety  
for your work*