



# Flex Lifting

---

a brand of AxA Group

**RANGE OF  
BELOW THE HOOK ACCESSORIES  
01.09.2024**

[www.flexlifting.com](http://www.flexlifting.com)

Flex Lifting - a brand of AxA Group srl  
Via Morandi 21, 40060 Toscanella di Dozza (Bologna) Italy Tel +39 0542673434 email: [info@flexlifting.com](mailto:info@flexlifting.com)



# LBF250 LIFTING BEAM - CAPACITY 250 KG

With galvanized finish and 2 standard swivel hooks

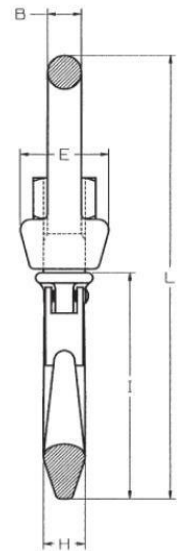
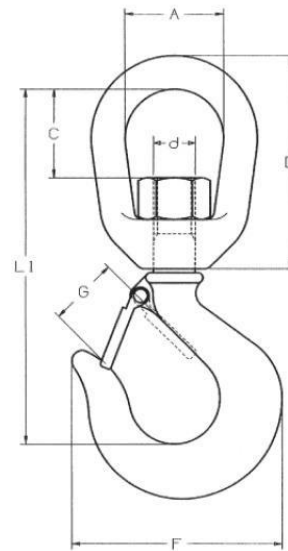
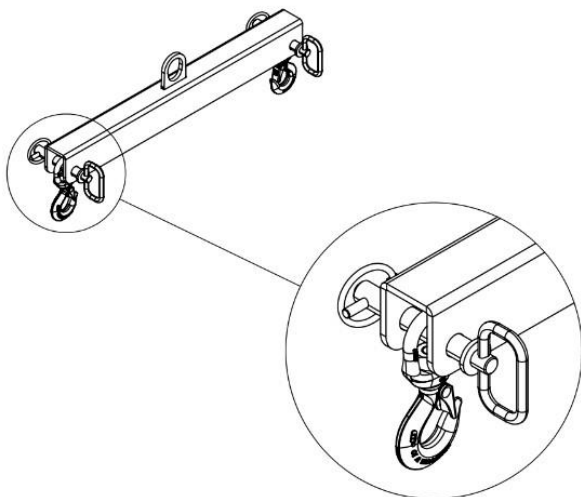
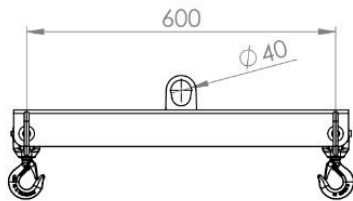
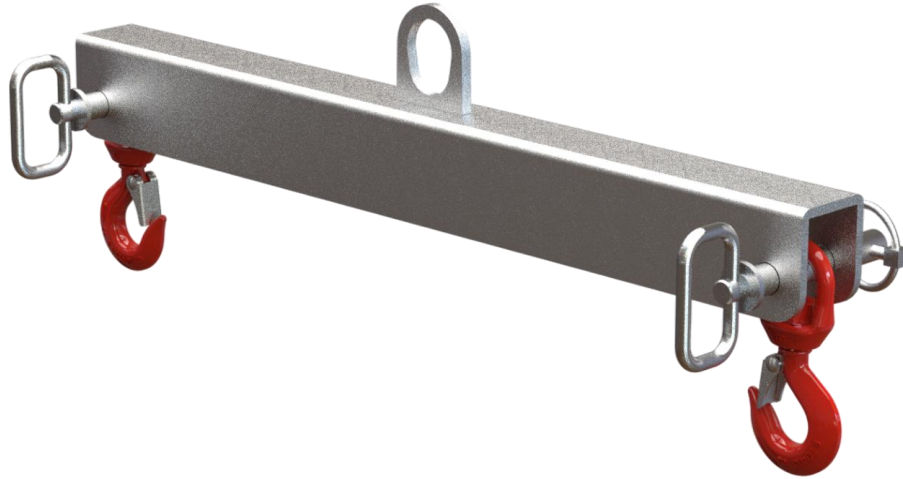

A	B	C	D	E	F	G	H	I	L	L1	d
mm	mm	mm	mm	mm	mm	mm	mm	mm	mm	mm	
39	13	33	81	34	81	17	19	87	170	135	M 16

[www.flexlifting.com](http://www.flexlifting.com)

Flex Lifting - a brand of AxA Group srl

Via Morandi 21, 40060 Toscanella di Dozza (Bologna) Italy Tel +39 0542673434 email: [info@flexlifting.com](mailto:info@flexlifting.com)



# LBF500 LIFTING BEAM - CAPACITY 500 KG

With galvanized finish and 2 standard swivel hooks

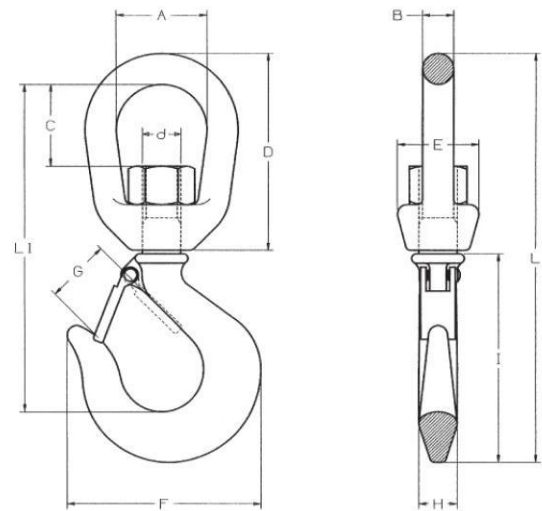
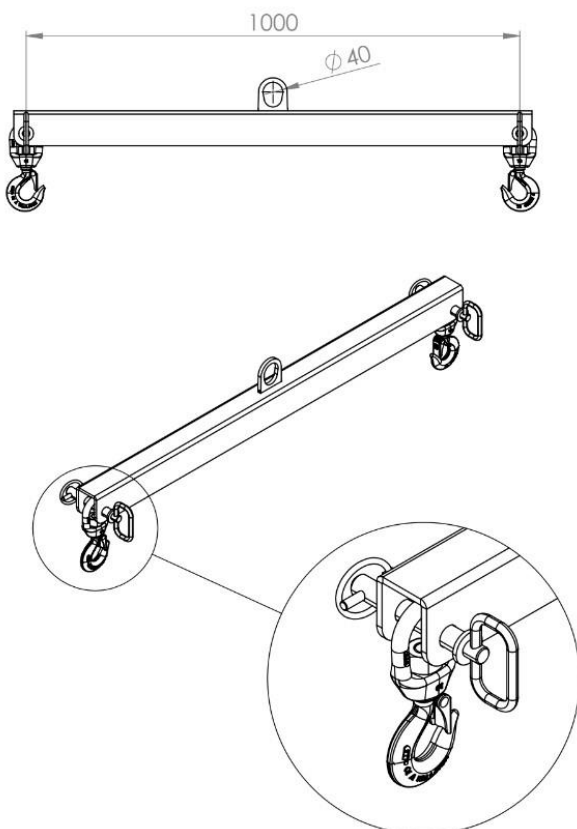
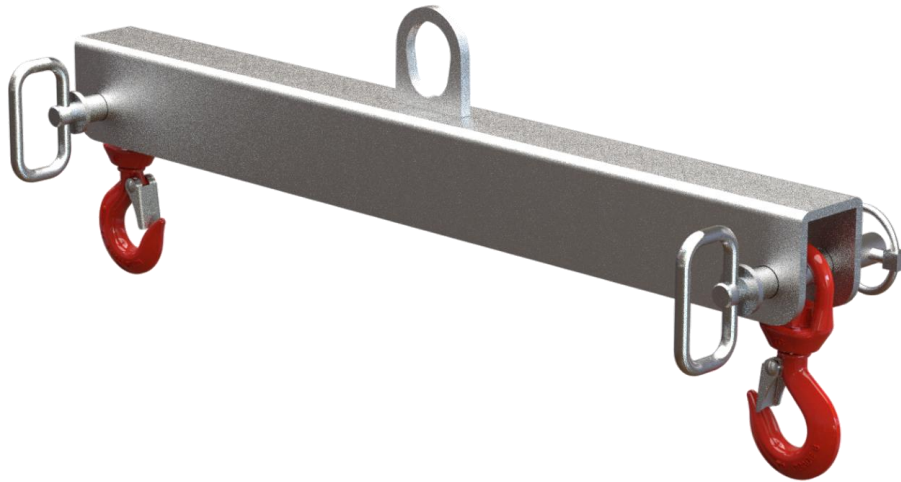

A	B	C	D	E	F	G	H	I	L	L1	d
mm	mm	mm	mm	mm	mm	mm	mm	mm	mm	mm	
39	13	33	81	34	81	17	19	87	170	135	M 16

[www.flexlifting.com](http://www.flexlifting.com)



# LBA250 ADJUSTABLE LIFTING BEAM - CAPACITY 250 KG

With galvanized finish and 2 standard swivel hooks

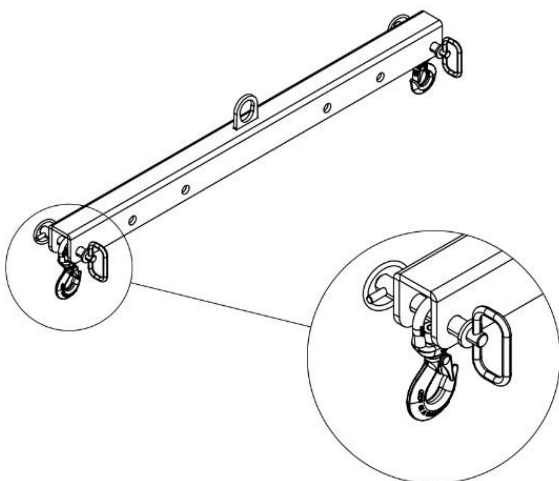
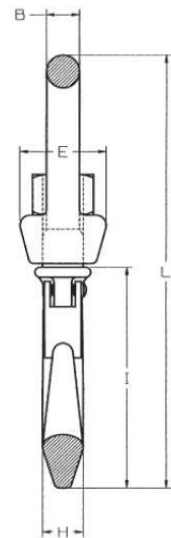
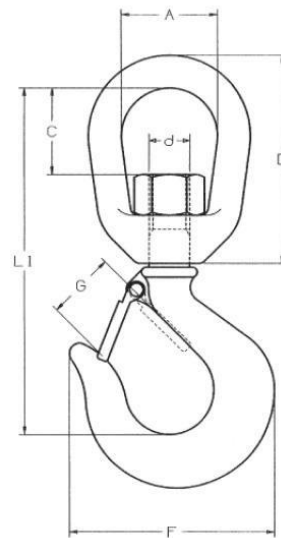
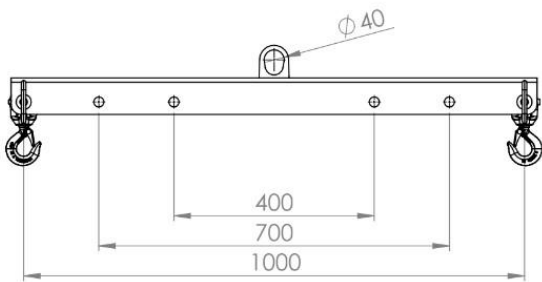
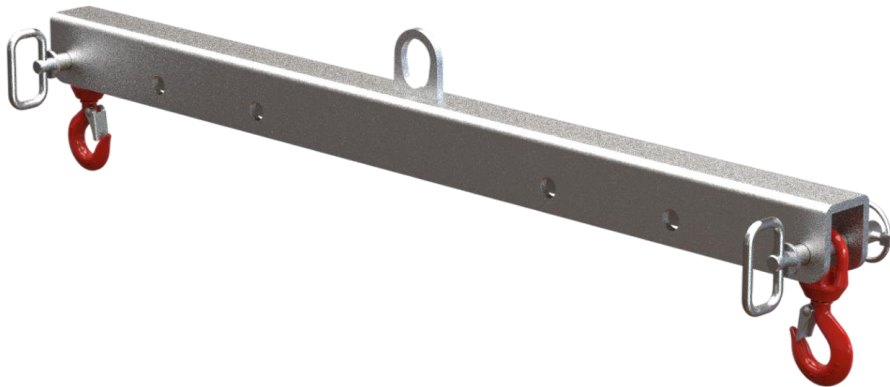

A	B	C	D	E	F	G	H	I	L	L1	d
39	13	33	81	34	81	17	19	87	170	135	M 16

[www.flexlifting.com](http://www.flexlifting.com)

Flex Lifting - a brand of AxA Group srl

Via Morandi 21, 40060 Toscanella di Dozza (Bologna) Italy Tel +39 0542673434 email: [info@flexlifting.com](mailto:info@flexlifting.com)



# LBA500 ADJUSTABLE LIFTING BEAM - CAPACITY 500 KG

With galvanized finish and 2 standard swivel hooks

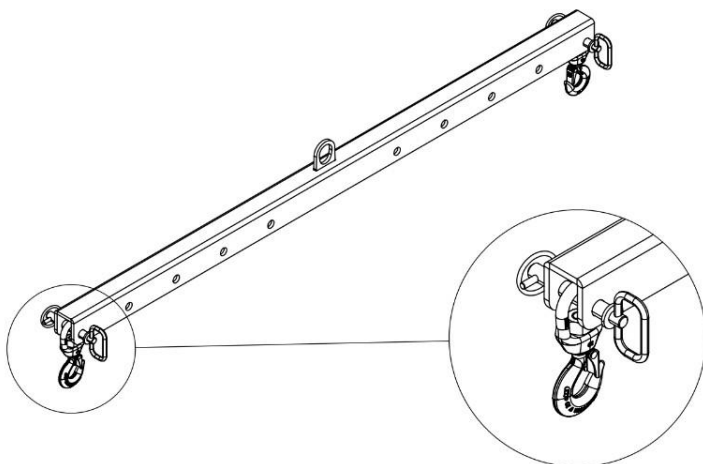
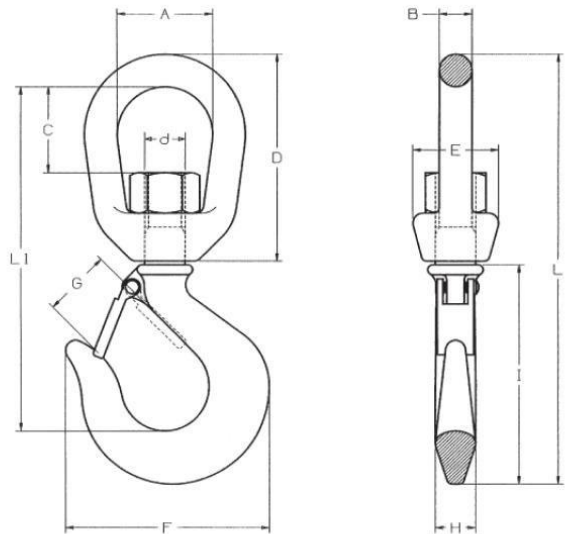
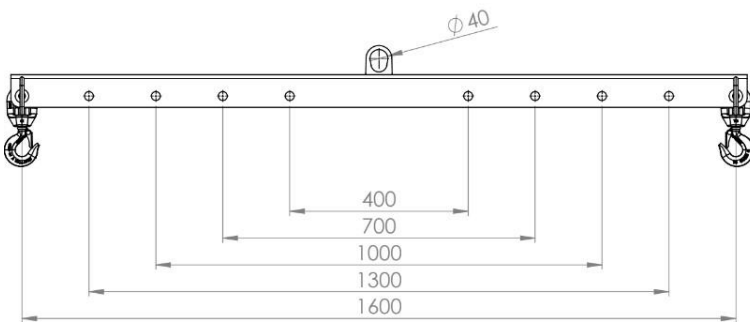
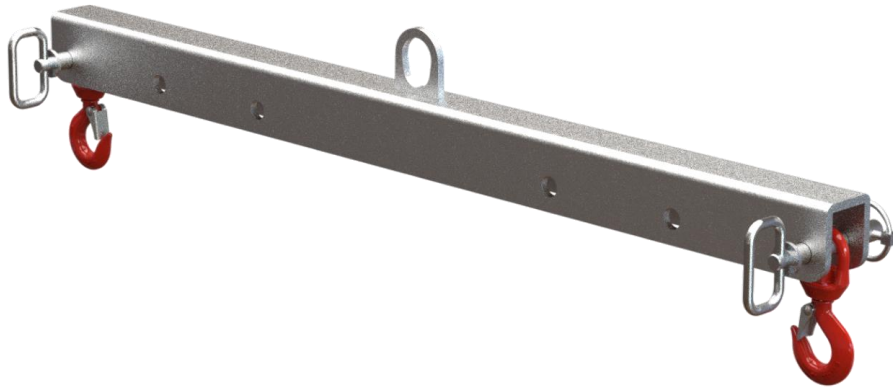

A	B	C	D	E	F	G	H	I	L	L1	d
39	13	33	81	34	81	17	19	87	170	135	M 16

[www.flexlifting.com](http://www.flexlifting.com)



# LBAC250 CROSS LIFTING BEAM - CAPACITY 250 KG

With galvanized finish and 4 standard swivel hooks

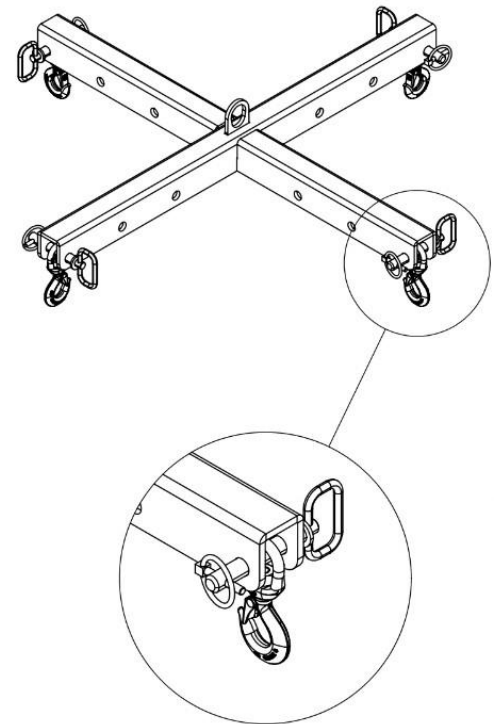
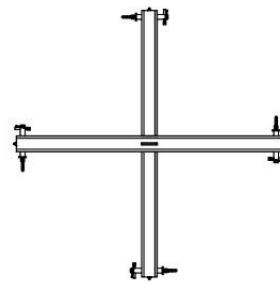
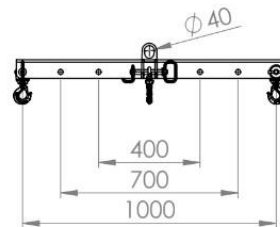
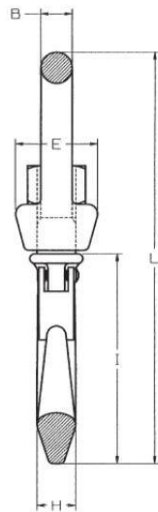
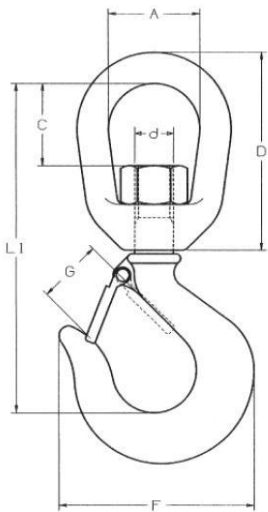

A	B	C	D	E	F	G	H	I	L	L1	d
mm	mm	mm	mm	mm	mm	mm	mm	mm	mm	mm	
39	13	33	81	34	81	17	19	87	170	135	M 16

[www.flexlifting.com](http://www.flexlifting.com)

Flex Lifting - a brand of AxA Group srl

Via Morandi 21, 40060 Toscanella di Dozza (Bologna) Italy Tel +39 0542673434 email: [info@flexlifting.com](mailto:info@flexlifting.com)



# LBAC500

## CROSS LIFTING BEAM - CAPACITY 500 KG

With galvanized finish and 4 standard swivel hooks

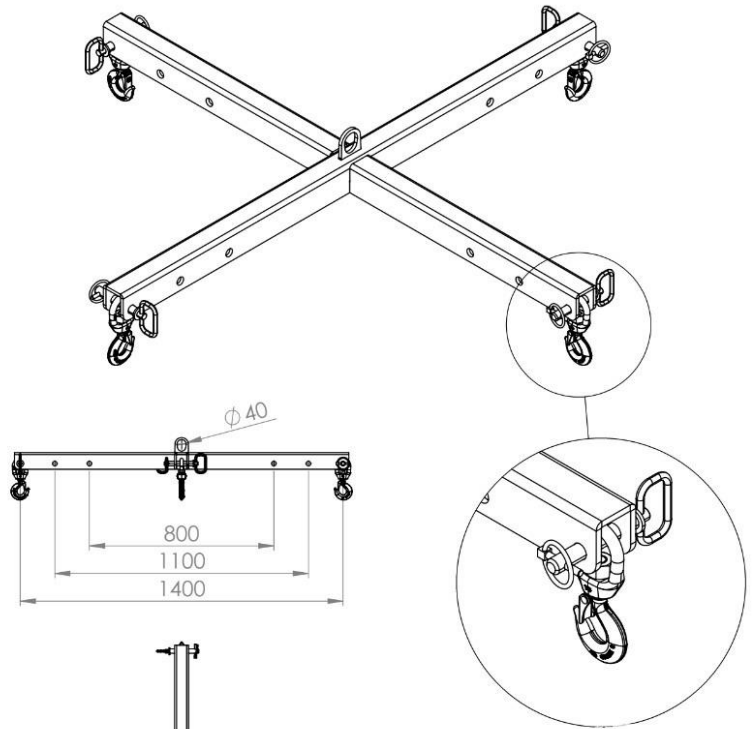
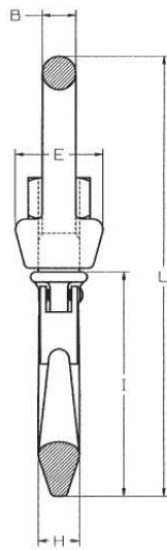
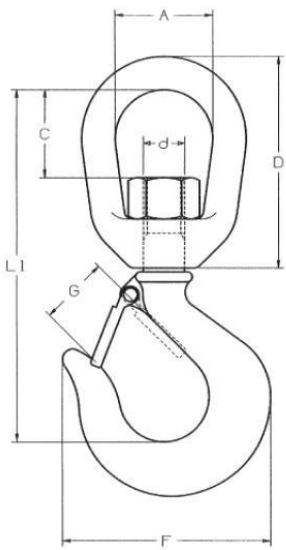

A	B	C	D	E	F	G	H	I	L	L1	d
mm	mm	mm	mm	mm	mm	mm	mm	mm	mm	mm	
39	13	33	81	34	81	17	19	87	170	135	M 16

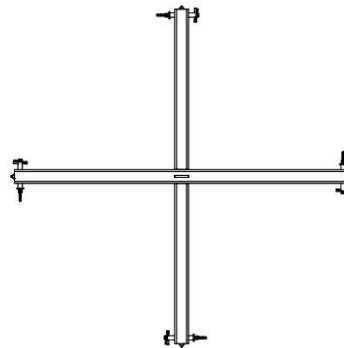

[www.flexlifting.com](http://www.flexlifting.com)



# FPE250

## BATTERY POWERED CHAIN HOIST - CAPACITY 250 KG

Portable battery powered electric hoist with 5 mt chains.

Lifting capacity 250 kg.

Charger, 2 Lithium batteries and case included.

Lifting speed 2,2 m/min. - 18V power supply.

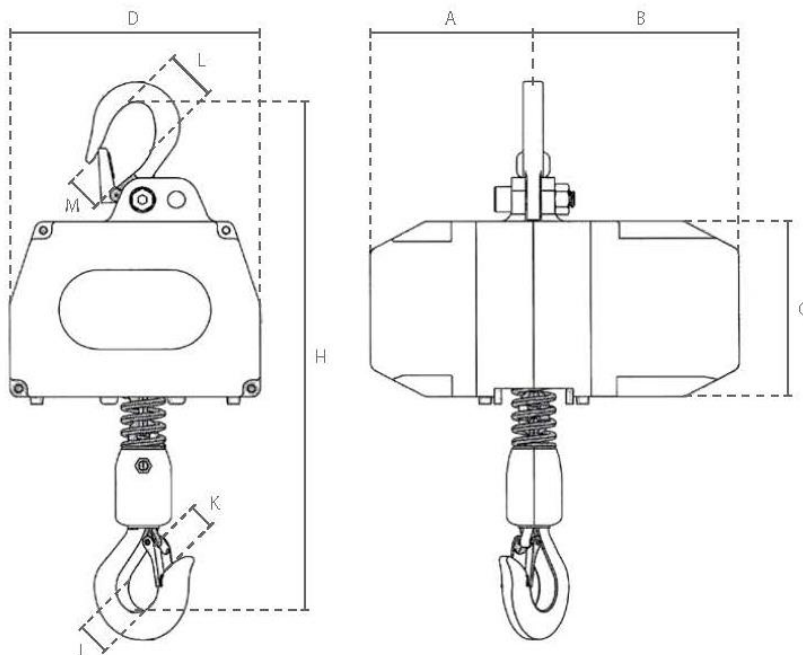

A	B	C	D	H	J	K	L	M
114	144	122	173	355	29	19	27	20

[www.flexlifting.com](http://www.flexlifting.com)

Flex Lifting - a brand of AxA Group srl

Via Morandi 21, 40060 Toscanella di Dozza (Bologna) Italy Tel +39 0542673434 email: [info@flexlifting.com](mailto:info@flexlifting.com)





# FPE500

## BATTERY POWERED CHAIN HOIST - CAPACITY 500 KG

Portable battery powered electric hoist with 5 mt chains.

Lifting capacity 500 kg.

Charger, 2 Lithium batteries and case included.

Lifting speed 2,2 m/min. - 18V power supply.

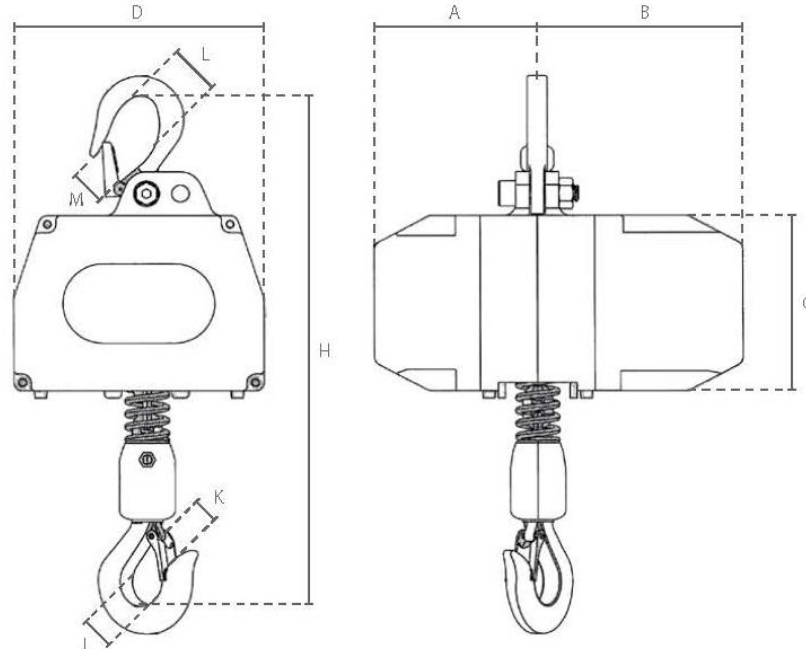

A	B	C	D	H	J	K	L	M
114	144	122	173	375	29	19	27	20

[www.flexlifting.com](http://www.flexlifting.com)

Flex Lifting - a brand of AxA Group srl

Via Morandi 21, 40060 Toscanella di Dozza (Bologna) Italy Tel +39 0542673434 email: [info@flexlifting.com](mailto:info@flexlifting.com)



## FX SERIES UNIVERSAL PERMANENT LIFTING MAGNETS

In the standard design, the FX lifting magnets have a broad spectrum of applications. The FX has good results with a large air gap as well as with thin, flat and round materials. A feature of this product is its highly sturdy nature and a good price performance. Made in Germany. Standard conformity CE/EN 13155/MRL 2006/42 EWG

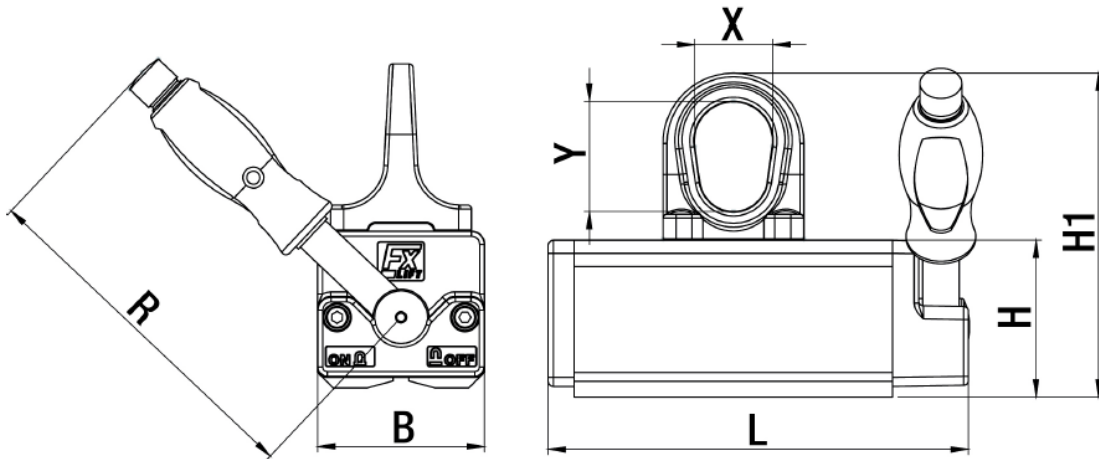

MODEL	MAX LOAD CAPACITY (kg)		MAX LOAD CAPACITY FROM(mm)	DIMENSIONS (mm)						WEIGHT kg
	FLAT	ROUND		L	B	H	H1	R	X/Y	
FX 150	150	diam 50-200 mm 75 kg	8	161	64	60	124	136	30/42	3.6
FX 300	300	diam 50-300 mm 150 kg	15	205	87	78	158	190	42/53	8.4
FX 600	600	diam 80-400 mm 300 kg	20	288	112	94	189	228	51/62	19
FX 1000	1000	diam 100-450 mm 500 kg	25	361	152	120	240	261	60/76	42
FX 2000	2000	diam 120-600 mm 1000 kg	50	472	228	169	313	409	68/89	115

Safety Factor 3.5 – Test Method EN 13155 – Max. operation temperature 80°C

[www.flexlifting.com](http://www.flexlifting.com)

Flex Lifting - a brand of AxA Group srl

Via Morandi 21, 40060 Toscanella di Dozza (Bologna) Italy Tel +39 0542673434 email: [info@flexlifting.com](mailto:info@flexlifting.com)



# FX-R SERIES PERMANENT LIFTING MAGNETS FOR ROUND MATERIAL

FX-R is the lifting magnet series for round material handling. The deep, flat angle prism ensures a secure position on the load and conducts the magnet field into the interior of the material.

The magnet system can be activated over the entire diameter, without being rebounded.

Even thin, flat material is not a problem for the FX-R. Made in Germany.

Standard conformity CE/EN 13155/MRL 2006/42 EWG

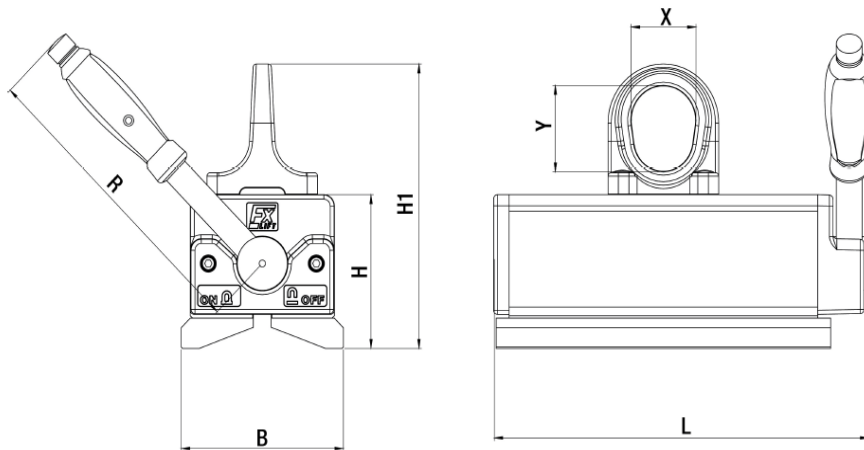

MODEL	MAX LOAD CAPACITY (kg)		MAX LOAD CAPACITY FROM(mm)	DIMENSIONS (mm)						WEIGHT kg
	FLAT	ROUND		L	B	H	H1	R	X/Y	
FX R100	100	diam 25-150 mm 100 kg	8	161	70	68	132	136	30/42	4
FX R225	225	diam 50-205 mm 225 kg	10	205	98	90	170	190	42/53	9.5
FX R450	450	diam 50-270 mm 450 kg	20	288	126	112	207	228	51/62	22
FX R750	750	diam 70-370 mm 750 kg	20	361	170	142	262	261	60/76	49
FX R1200	1200	diam 120-560 mm 1200 kg	40	472	248	190	334	409	68/89	127
FX R1800	1800	diam 120-560 mm 1800 kg	40	648	248	190	334	534	68/89	182

Safety Factor 3.5 – Test Method EN 13155 – Max. operation temperature 80°C

[www.flexlifting.com](http://www.flexlifting.com)

Flex Lifting - a brand of AxA Group srl

Via Morandi 21, 40060 Toscanella di Dozza (Bologna) Italy Tel +39 0542673434 email: [info@flexlifting.com](mailto:info@flexlifting.com)



# FX-P SERIES PERMANENT LIFTING MAGNETS FOR THIN METAL SHEETS AND PIPES

FX-P is the lifting magnet series for professional lifting and moving thin plates, tubes and rods. The special magnet-configuration, which is connected with the FX-P prismatic pole, ensures a maximum magnetic flux density with thin material as well.

The FX-P can be well positioned and easy activated on a round material. Made in Germany. Standard conformity CE/EN 13155/MRL 2006/42 EWG.

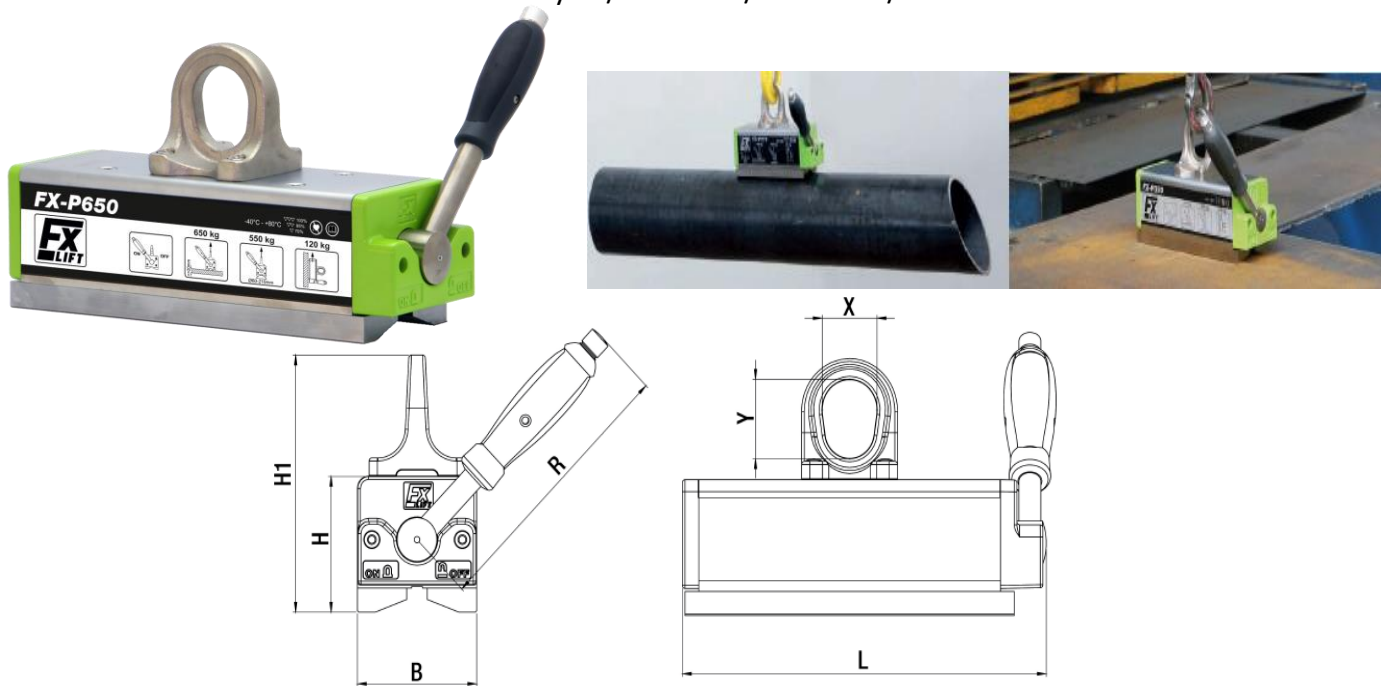

MODEL	MAX LOAD CAPACITY FOR SHEETS AND 4-EDGE PIPES (kg)						L X B Max. ( mm )	PIPES Diam. ( mm )	CAPACITY (kg) / Thick. ( mm )
	3 mm	4 mm	6 mm	8 mm	10 mm	15 mm			
FX P170	50	80	120	170	170	170	2000X1250	diam.30 - 105	150/8 mm
FX P330	70	100	160	300	330	330	2500X1250	diam.40 - 160	300/10 mm
FX P650	100	160	200	450	530	650	3000X1500	diam.60 - 210	550/20 mm

MODEL	MAX LOAD CAPACITY (kg)		MAX LOAD CAPACITY FROM(mm)	DIMENSIONS (mm)						WEIGHT kg
	FLAT	ROUND		L	B	H	H1	R	X/Y	
FX P170	170	diam 30-105 mm 100 kg	8	195	64	70	134	136	30/42	5.1
FX P330	330	diam 40-160 mm 300 kg	10	265	87	90	170	190	42/53	12.4
FX P650	650	diam 60-210 mm 550 kg	20	352	112	106	203	228	51/62	26

Safety Factor 3.5 – Test Method EN 13155 – Max. operation temperature 80°C

[www.flexlifting.com](http://www.flexlifting.com)

Flex Lifting - a brand of AxA Group srl

Via Morandi 21, 40060 Toscanella di Dozza (Bologna) Italy Tel +39 0542673434 email: [info@flexlifting.com](mailto:info@flexlifting.com)



# FX-V SERIES

## PERMANENT LIFTING MAGNETS WITH 90° PRISM FOR BEAMS, PROFILES AND HOT PARTS

FX-V Lifting Magnets are geared to particular areas of application in steel, ship and container building. Because of the 90° prism, the angle profiles can be lifted safely. While lifting hot flame cuts, the deep prism protects the inserted magnets from the heat. The FX-V will be activated by a single stable, smooth running lever. Made in Germany.  
Standard conformity CE/EN 13155/MRL 2006/42 EWG

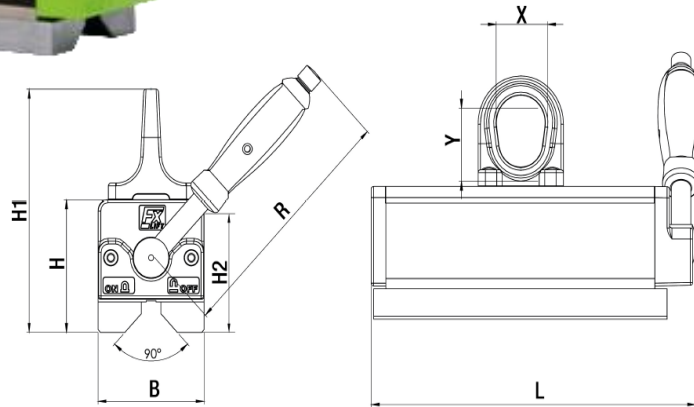

MODEL	H2 (mm)	IPE	HEB
FX V200	65	from 80	from 100
FX V400	87	from 100	from 120
FX V800	106	from 140	from 160

MODEL	MAX LOAD CAPACITY (kg)		MAX LOAD CAPACITY FROM(mm)	DIMENSIONS (mm)						WEIGHT kg
	FLAT	ROUND		L	B	H	H1	R	X/Y	
FX R100	100	diam 25-150 mm 100 kg	8	161	70	68	132	136	30/42	4
FX R225	225	diam 50-205 mm 225 kg	10	205	98	90	170	190	42/53	9.5
FX R450	450	diam 50-270 mm 450 kg	20	288	126	112	207	228	51/62	22

Safety Factor 3.5 – Test Method EN 13155 – Max. operation temperature 80°C

[www.flexlifting.com](http://www.flexlifting.com)

Flex Lifting - a brand of AxA Group srl

Via Morandi 21, 40060 Toscanella di Dozza (Bologna) Italy Tel +39 0542673434 email: [info@flexlifting.com](mailto:info@flexlifting.com)



## FX-HV SERIES HORIZONTAL – VERTICAL SYSTEM

The FX-HV Horizontal – Vertical System with its various settings can satisfy all requirements. Pins can adjust the total height and the barycenter. The support pins are positioned in such a way that vertical, circular blanks can be lifted, which is mostly needed on the saw. They can also lift washers and sheets. For horizontal transport, the system has a crane eyelet on the back. The steel construction is stable with a completely powder coated surface and the FX lifting magnet ensures maximum safety. Special dimensions are available on request. Made in Germany.  
Standard conformity CE/EN 13155/MRL 2006/42 EWG.

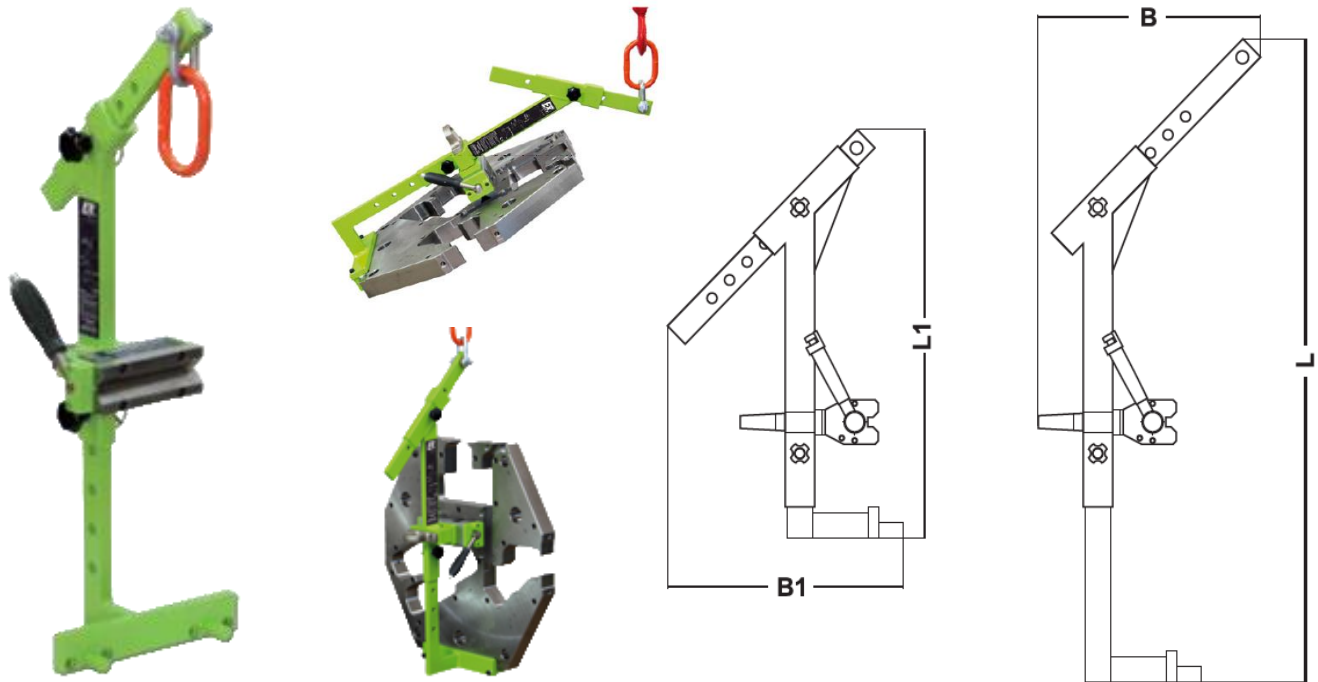

MODEL	MAX MATERIAL DIMENSION ( mm )		MAX LOAD CAPACITY		DIMENSIONS ( mm )				WEIGHT kg
	FLAT	ROUND	WITH STOP	WITHOUT STOP	L	B	L1	B1	
			( kg )	( kg )					
FX HV 200	2000X750	diam 250-750	200	40	1000	400	715	390	24
FX HV 400	2000X100	diam 400-1000	400	80	1250	450	795	475	31
FX HV 800	2500X125	diam 500-1200	800	160	1500	500	1040	520	64
FX HV 2000	2500X125	diam 500-1200	2000	400	1800	600	1200	650	250
FX HV 3000	2500X125	diam 500-1200	3000	600	1800	600	1200	650	320

Safety Factor 3.5 – Test Method EN 13155 – Max. operation temperature 80°C

[www.flexlifting.com](http://www.flexlifting.com)

Flex Lifting - a brand of AxA Group srl

Via Morandi 21, 40060 Toscanella di Dozza (Bologna) Italy Tel +39 0542673434 email: [info@flexlifting.com](mailto:info@flexlifting.com)



## FX-LT SERIES PERMANENT LIFTING MAGNET TRUSS

FX-LT Magnet Traverses will be adapted to the needs of sheet metal fabricators, laser cutters and flame cutters. Two FX-V lifting magnets within a certain distance, strengthened by a traverse with two-chain suspensions, allow loading and unloading of machines with sheets or the vertical lifting of work-pieces with a center cutout. With a few simple hand movements, the magnets can be removed from the traverse for lifting blanks and small plates with only one magnet.

Made in Germany. Standard conformity CE/EN 13155/MRL 2006/42 EWG.

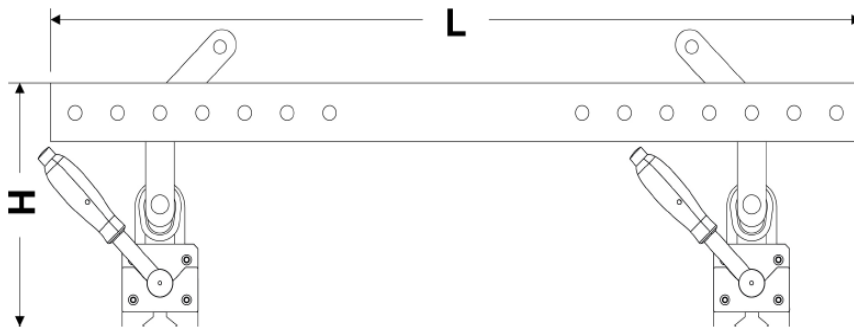

MODEL	Incl 2x FX	MAX LOAD CAPACITY		MAX Workpiece dim ( mm )	DIMENSIONS ( mm )		WEIGHT kg
		( kg )	from ( mm )		L	B	
FX LT 600	FX P330	600	10	4000x1500	1600	270	44
FX LT 700	FX V400	700	15	5000x1500	1600	270	44
FX LT 1000	FX 600	1000	20	5000x1500	1600	291	58
FX LT 1400	FX V800	1400	20	5000x2000	1600	360	86
FX LT 3200	FX 2000	3200	50	5000x2500	2000	480	305
FX LT 4800	FX 3000	4800	50	5000x2500	2000	600	410

Safety Factor 3.5 – Test Method EN 13155 – Max. operation temperature 80°C

[www.flexlifting.com](http://www.flexlifting.com)

Flex Lifting - a brand of AxA Group srl

Via Morandi 21, 40060 Toscanella di Dozza (Bologna) Italy Tel +39 0542673434 email: [info@flexlifting.com](mailto:info@flexlifting.com)



## FX-C SERIES MAGNETIC LIFTERS FOR RINGS AND FLANGE PLATES

FX-C lifting magnets have a round multi-pole anchorage surface, designed for lifting rings, bushings, bearing housings, flange plates and similar parts. The load specification is valid for the contact of the entire surface with pieces that overlap from the inside to the outside. Parts with a smaller contact surface can have a capacity of 3.5 kg max. per cm<sup>2</sup> of surface. Made in Germany. Standard conformity CE/EN 13155/MRL 2006/42 EWG.

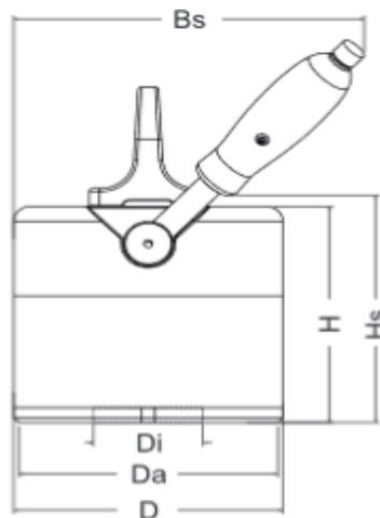

MODEL	MAX CAPACITY from thickness ( mm )	CAPACITY ( kg )	CAPACITY per cm <sup>2</sup> ( kg )	DIMENSIONS ( mm )					WEIGHT kg
				D	Da.Di	H	Hs	Bs	
FX – C175	10	175	3,5	120	114-40	130	138	185	7,5
FX – C250	12	250	3,5	160	152-65	145	153	210	15
FX – C450	15	450	3,5	250	240-100	155	168	275	35
Safety Factor 3.5 – Test Method EN 13155 – Max. operation temperature 80°C									

[www.flexlifting.com](http://www.flexlifting.com)

Flex Lifting - a brand of AxA Group srl  
Via Morandi 21, 40060 Toscanella di Dozza (Bologna) Italy Tel +39 0542673434 email: [info@flexlifting.com](mailto:info@flexlifting.com)